



USER MANUAL

Installation, Operation and Maintenance Manual



**Series: SP**

Pressure Transmitters

## Contents

Introduction . . . . .	3
Models & Dimension . . . . .	4
Electrical Connection . . . . .	7
Mounting Notes . . . . .	10
Installation . . . . .	11
Calibration . . . . .	13
Handling . . . . .	14
Technical Specification . . . . .	15
Trouble Shooting . . . . .	23
Ordering Information . . . . .	24
Warranty . . . . .	25

## SP Series Pressure Transmitter



The SP Series of pressure transmitters are designed to measure the level or pressure of various industrial processes.

Models can be mounted with various threaded or flanged process connections. All models are available with 4...20mA (2 wire) output (or voltage outputs). The SP/FA line comes with an integrated Zero and Span adjustment. All units offer excellent stability, repeatability, accuracy and temperature compensation. HART communications protocol is also available for many models.

Each model in this series is offered in pressure ranges that are suitable for various types of application requirements such as for; liquids, gases, areas with limited space, food industry, chemical industry or areas that feature aggressive mediums or waste fluids with varying degrees of suspended solids.

### **Technology**

The SP series utilize the principle of the alteration of resistance or capacitance. The SP Series is available with sensing elements of either 316 Stainless Steel, ceramic piezoresistive diaphragms or thick filmed ceramic diaphragms (for more aggressive mediums or applications).

The external pressure of the medium induces a dislocation of electrical load that accumulates on the opposite surface of the diaphragm, resulting in an output signal that is proportional to the pre-calibrated pressure range of the sensor. The electronics converts this information into either a 4...20mA(2 wire) output signal (standard) or a 1 to 5V (3 wire optional per custom order), which is directly proportional to the applied pressure of the process.

### **Characteristics**

- Small, robust and easy to install
- Reliable measurement of level and pressure.
- HART Communications Protocol is available (for most models)
- Available in a wide range of process connections: Threaded, Flanged or Sanitary
- Pressure range up to 1000 Bar (14500 PSI) depending on the model

## Models & Dimensions

### Pressure transmitters models (unit: mm)

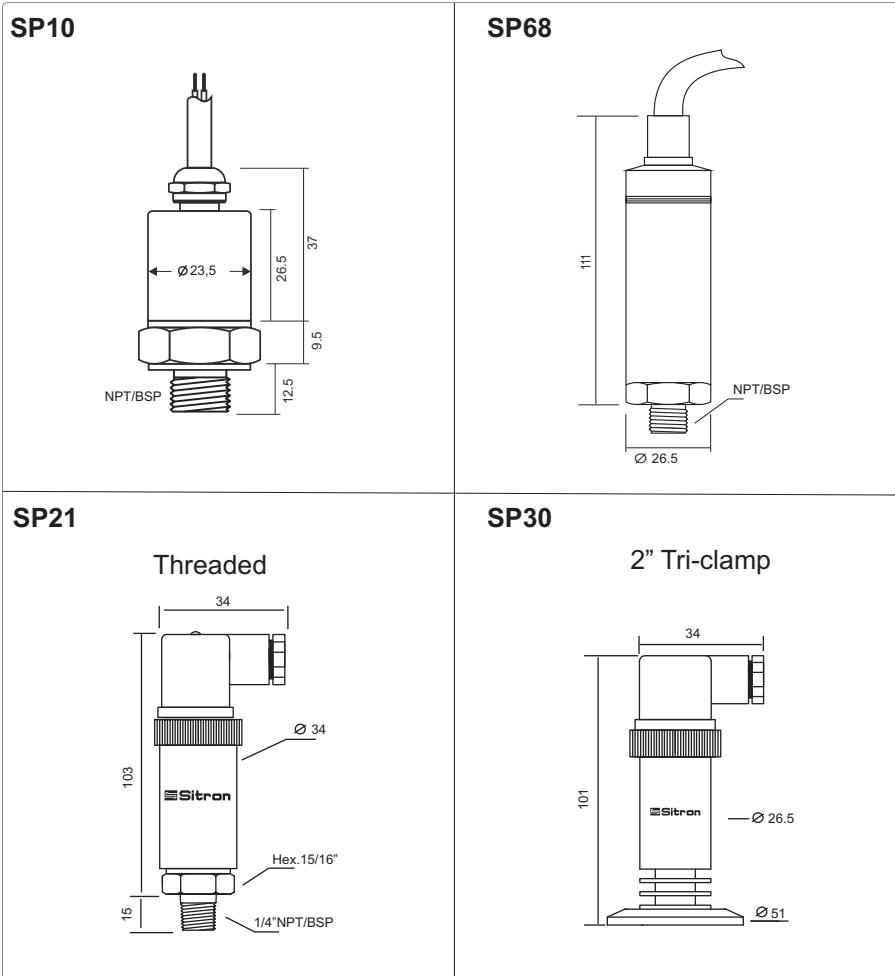

### SP21 Adapter

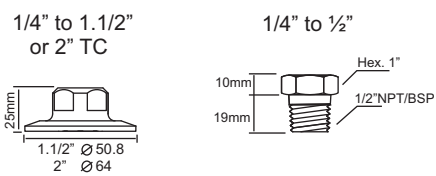

## Models & Dimensions

### SP98 (unit: mm)

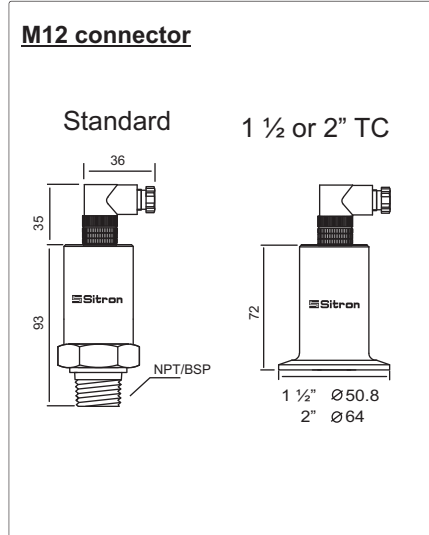
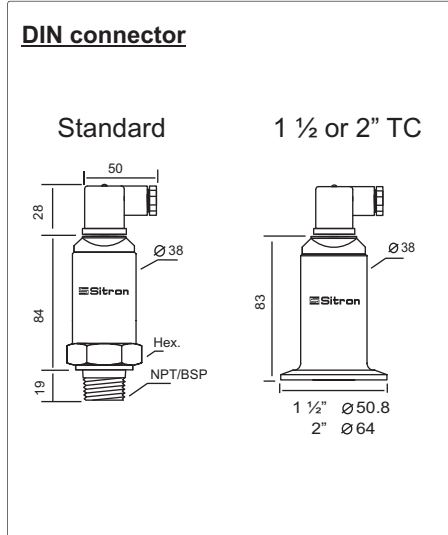

### SP96 (unit: mm)

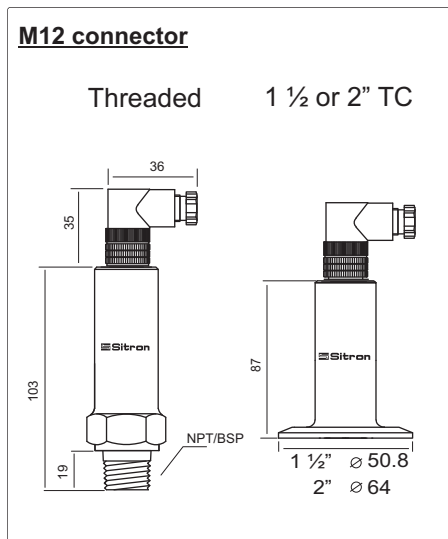

### SP81

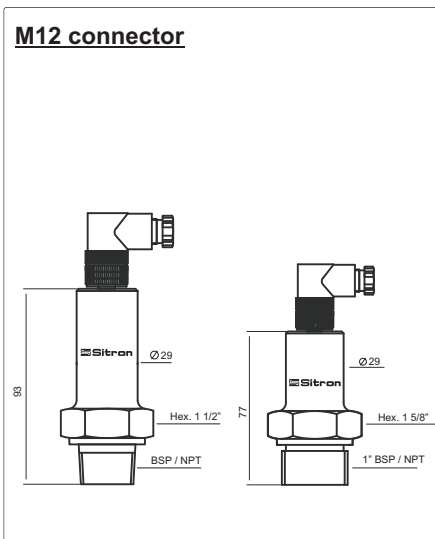

## Models & Dimensions

### SP98FA with Housing

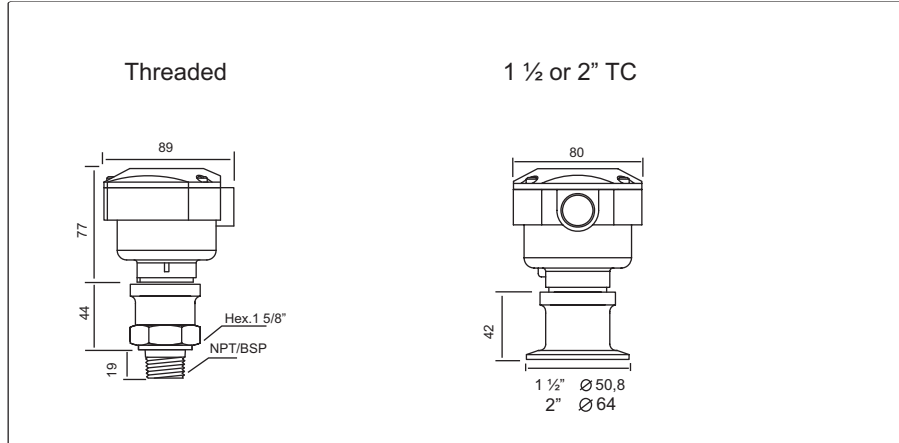

### SP96FA with Housing

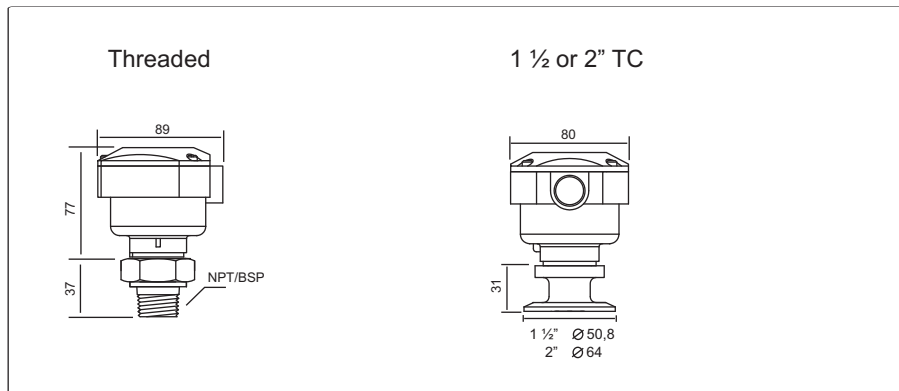

### Process Connections

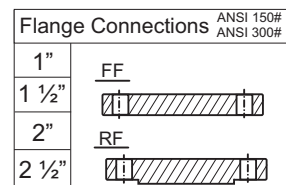
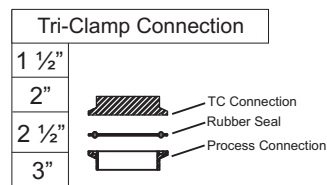
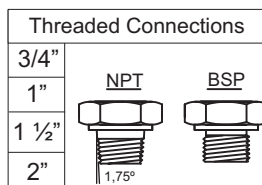

## Electrical Connections

**M12 connector  
2 and 3 wires**

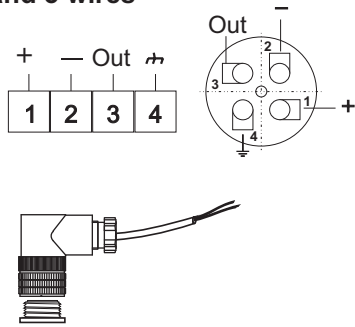

**DIN 43650 connector  
2 and 3 wires**

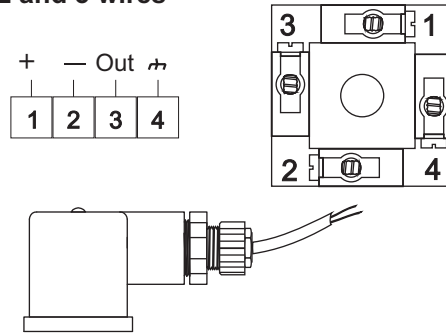

**4...20mA (2 wires)  
Passive**

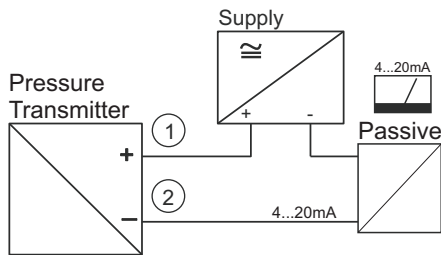

**4...20mA (2 wires)  
Active**

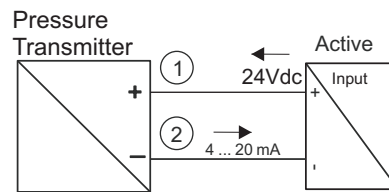

**1...5Vdc (3 wires)**

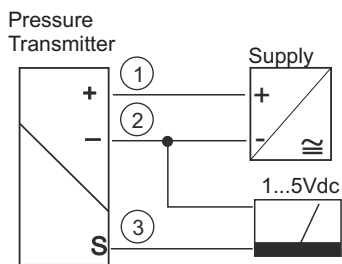

## Electrical Connections

### SP10 & SP68

#### 4...20mA (2 wires) Passive

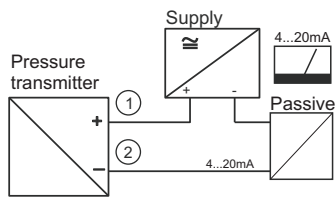

#### 4...20mA (2 wires) Active

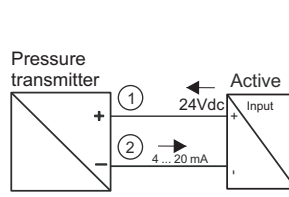

#### SP68

- ① Red (+)
- ② Black (-)

#### SP10

- ① Red (+)
- ② Green (-)

### 1...5Vdc

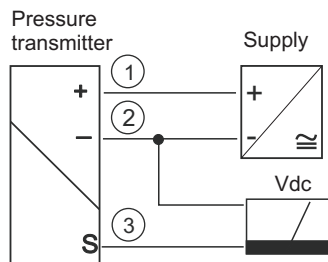

#### SP10

- ① Red (+)
- ② Green (-)
- ③ Yellow (Out) 3 wires

#### SP68

- ① Red (+)
- ② Black (-)
- ③ Yellow (Out) 3 wires

### HART Modem connection

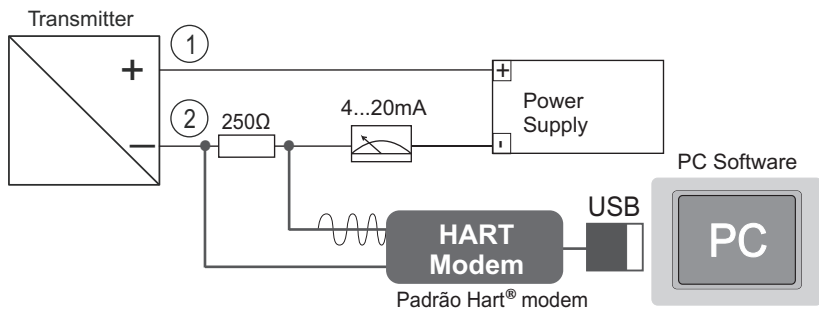



## Electrical Connections

### SP96FA & SP98FA

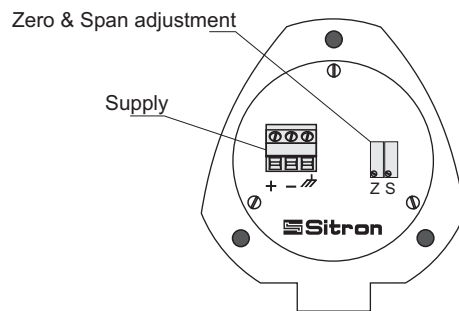

4...20mA (2 wires)

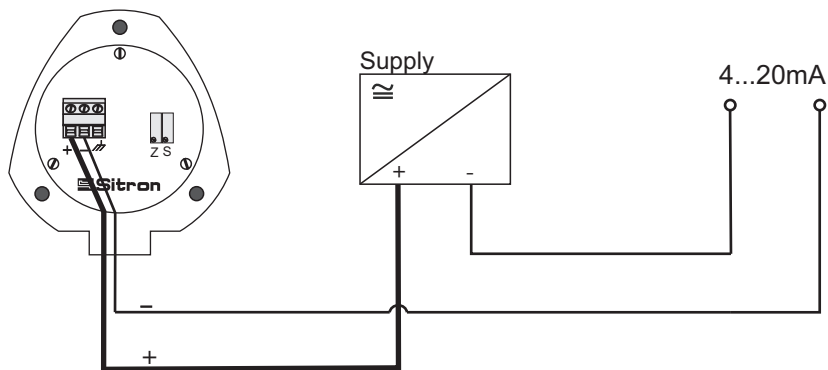

Load impedance

**SP96FA**

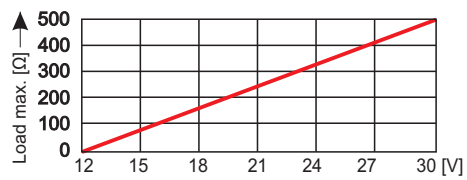

**SP98FA**

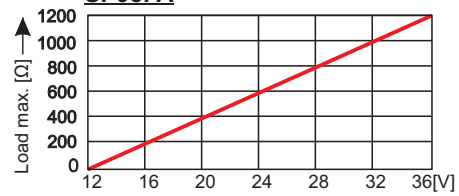

## Mounting Notes

1) Use PTFE tape or o'rings to seal the system.

### Transmitters with cable gland:

Tighten the cable gland as much as possible so that the cable is securely in place and cannot be pulled through the cable gland. This will help insure that no moisture is able to infiltrate into the housing. Don't forget to attach the housing cover and tighten all three screws into position so that there is no infiltration.

2) Before installing, make sure the cable connections are correct and that the line voltage is compatible with the specifications of the equipment. Use reliable cables and make sure that they are grounded. Shielded cables prevent interference and changes in the electronic signal, protecting against false measurement output. Avoid radio frequency interference as it may also cause false signals and even create a possible malfunction of the transmitter. When possible, keep hand held communication equipment away from the SP transmitter.

3) Care should be taken to prevent deformities in the membrane. You should also be careful not to touch or let any other object touch the membrane of the sensor during installation (this does not apply to the units with ceramic sensing elements). Any deformity to the surface of the 316SS silicone filled membrane will damage the sensor and impair its operation.

4) Protect the transmitter against rain and do not expose it to excessive heat. Respect the working temperature and the class protection specified for use.

5) Before installation, for security reasons, make sure the tank or pipe is empty and without pressure.

### 6) For transmitters with sealing:

Under no circumstances should you remove the transmitter seal. Avoid flexing the membrane with your hands and keep it protected until the installation.

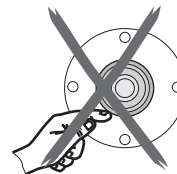
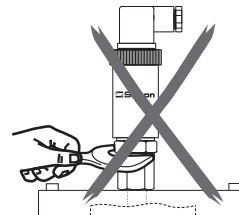
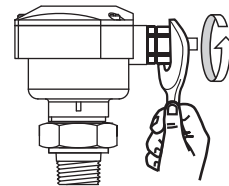
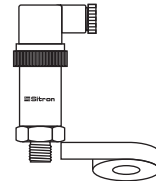

## Installation

### Pressure of the Liquid Column

Water Column	System MKgfs	System MKS
$P(\text{mH}_2\text{O}) = \text{relative density} \cdot h(\text{m})$	$P(\text{Kg/m}^2) = \text{Specific Gravity}(\text{Kg/m}^3) \cdot h(\text{m})$	$P(\text{KPa}) = \text{density}(\text{Kg/m}^3) \cdot g(\text{m/s}) \cdot h(\text{m})$

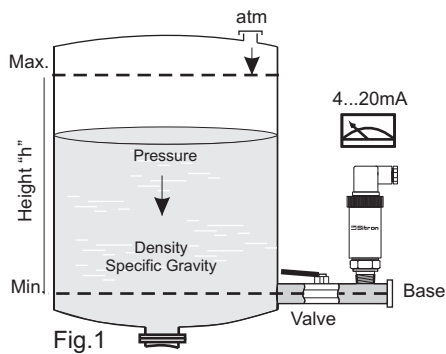

#### Principle of Operations

The weight of the column of liquid generates hydrostatic pressure on the diaphragm of the sensor. When the density of the product is constant and the quantity of the liquid is increased or decreases, there will be a proportional output from the sensor.

The transmitters can be installed in various positions, but the following needs to be taken into account: For level measurement the installation should be at the base of the tank or at the point of minimum level measurement (fig.1). This means that the reference point for the base measurement will become the point at which the sensor is installed which will not necessarily be at the bottom of the tank.

It is advisable to install a blocking valve between the transmitter and the connection to perform maintenance without having to stop the process.

Avoid installing in the tank outlet or near shaker where there is pressure pulses thus preventing rapid changes in the signal. For this case it is necessary the use of still-pipe (Stilling tube) to absorb the liquid surfaces (Fig. 2).

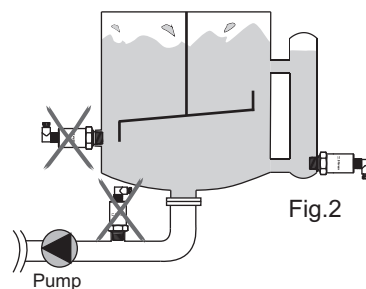

In situations where the tank is suspended, the transmitter should always be installed in a point below the connection using the sealing system with capillary connection. This type of installation is required when you want to mount the transmitter in a better position for viewing (Fig. 3).

Note: Evaluate what type of product is to be measured. Aggressive products can damage the membrane of the sensor element or of the o-ring seal. That is why it is necessary to determine the compatibility of the product before the unit is purchased and installed. (Fig. 4).

Install the transmitter so that the electrical cable dips below the transmitter (or makes a "U") so that water can drain off the cable without the risk of infiltrating into the transmitter (Fig 5).

Use a cable with vent tube for all Sitron transmitter models so that the linearity of the output signal and the operation of the unit is not compromised (this special cable can also be provided by Sitron) (Fig. 7).

Avoid installing the transmitter underneath a tank or where splashing or overflow of the product might damage the unit. If this is unavoidable, install a barrier to protect the unit from the product infiltrating from the outside of the transmitter. This may also be recommended when the installation is in an open environment. Weather variations can create internal condensation, so it is best to avoid exposing the transmitter to direct

Fig. 3

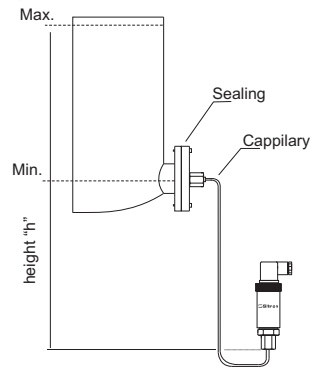

Fig. 4

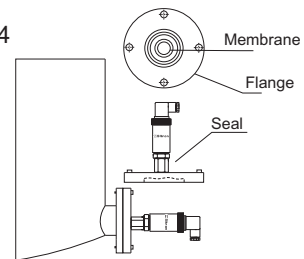

Fig. 5

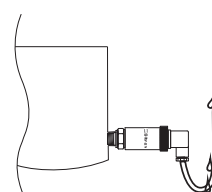
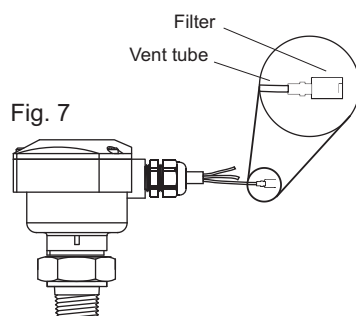
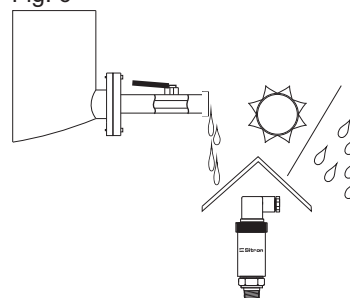

Fig. 6



## Calibration

### **SP98FA and SP96FA**

Before the calibration of the unit is first tested, the process should be free of pressure or (if that is not possible) the unit should first be tested outside of the vessel.

Make sure the multi-meter is correctly connected in series with the source and the instrument. The scale should be set to mA

First confirm that the current output is at 4mA (for SPFA units you can adjust the trimpot "zero".) Turning the trimpot clockwise increases the current value, and turning it counterclockwise decreases the value (Fig.2).

After adjusting (if necessary) the 4mA (zero) install the unit in the process or fill the vessel to increase the pressure of the process to the maximum level desired. If necessary, turn the trimpot (Span) to adjust the 20mA signal (Fig.3).

After calibrating the unit for the first time, it is recommended that you re-check the zero and span output with your multimeter. This will confirm that the unit is properly calibrated or if further adjustment is necessary.

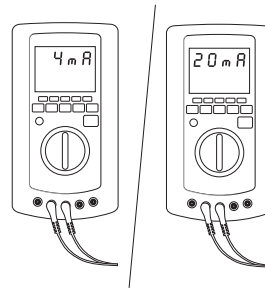

Fig.1

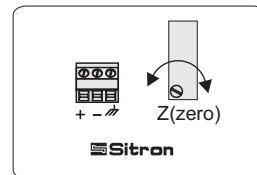
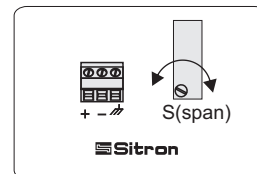

Fig.2



Seal the thread with Teflon tape before installation. Do not turn or handle by the housing (Fig. 1).

When tightening the sensor, use only use the 316S.S. hexagon fitting to achieve a seal, do not twist with the body of the sensor. (Fig. 2).

The transmitter should not be dropped or suffer any impact or fall, as this can damage the electronics or the sensor (Fig.3).

Do not insert any object into the entry point of the transmitter supply. This will immediately damage the membrane.

**Electrical connection with DIN connector:**

Figure 4. Shows the steps for proper assembly of the connector. When you tighten the threaded part, stop once you feel that the rubber seal is at its maximum compression point. Do not over-tighten the thread. It is very important that the connector is securely sealed so that the class protection is maintained and no infiltration occurs.

Fig. 1



Fig. 2

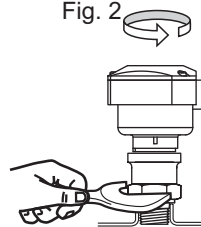

Fig. 3

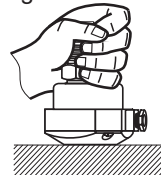
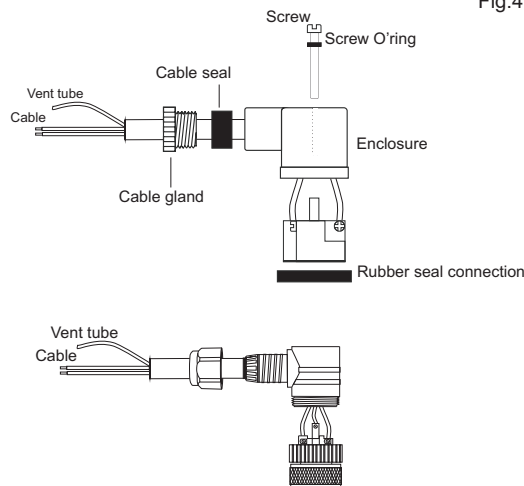
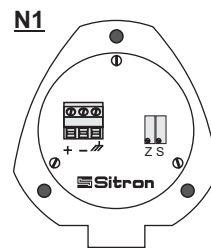
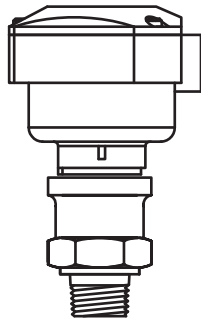

Fig.4



## Technical Specifications

### SP98FA



Application	Pressure and Level measurement for liquids and gas
Power supply	12...30Vdc
Consumption	22mA max.
Output	4...20mA (2 wires )
Accuracy	+/- 0.5%
Adjustment	Zero & Span
Sensor type	Ceramic capacitive
Range	-1 to 40 Bar
Electrical connection	Cable gland ½"NPT
Process connection	BSP or NPT - flange or sanitary
Housing	Fiberglass Nylon
Body material	316 SS
Work temperature	-10 to +80°C
Over pressure	3 x F.S.
Class protection	IP 65

## Technical Specifications

### SP96FA

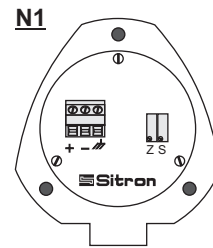
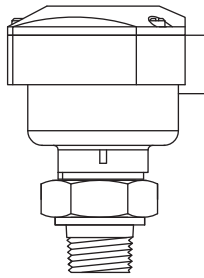

Application	Pressure and Level measurement for liquids and gas
Power supply	12...30Vdc
Consumption	22mA max.
Output	4...20mA (2 wires )
Accuracy	+/- 0.5%
Adjustment	Zero & Span
Sensor type	316 SS piezoresistive silicon
Range	-1 to 200 Bar
Electrical connection	Cable gland 1/2"NPT
Process connection	BSP or NPT - flange or sanitary
Housing	Fiberglass Nylon
Body material	316 SS
Work temperature	-10 to +80°C
Over pressure	3 x F.S.
Class protection	IP 65



## Technical Specifications

### SP68



- ① Red (+)
- ② Black (-)
- ③ Yellow (Out) 3 wires

Application	Pressure and Level measurement for liquids and gas
Power supply	12...30Vdc
Consumption	22mA max.
Protection	Reverse polarity
Output	4...20mA (2 wires )/ , 1...5V, 0...5V (3 wires)
Accuracy	+/- 0.5%
Sensor type	316 SS silicon piezoresistive
Range	0.1 to 1000 Bar
Electrical connection	Polyethylene
Process connection	M20*1.5" / 1/2"(BSP or NPT) (others)
Body material	304 SS
Work temperature	-10° to + 80°C
Over pressure	3 x F.S.
Class protection	IP 68

## Technical Specifications

### SP30

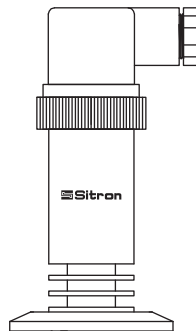

DIN 43650 Connector

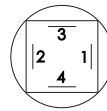

- 1** (+) Positivo
- 2** (-) Negativo
- 3** Out (V)
- 4** (⏏) GND

Application	Pressure and Level measurement for liquids and gas
Power supply	12...30Vdc
Consumption	22mA max.
Output	4...20mA (2 wires ) 0...4,5V (3 wires) upon request
Protection	Reversal polarity
Accuracy	+/- 0,5%
Sensor type	316 SS piezoresistive Silicon or olive oil
Range	0,1 to 1000 Bar
Electrical connection	DIN43650 or M12 connector
Process connection	M20*1.5 , 1/2" BSP or 2"TC
Body material	304 SS
Work temperature	0 to +80°C ( olive oil sensor) -10° a + 80°C ( silicon sensor)
Over pressure	3 x F.S.
Class protection	IP 65

## Technical Specifications

### SP10



- ① Red (+)
- ② Green (-)
- ③ Yellow (Out) 3 wires

Application	Pressure and Level measurement for liquids and gas
Power supply	12...30Vdc
Consumption	22mA max.
Protection	Reversal polarity
Output	4...20mA (2 wires ) 0...5 e 1...5V (3 wires)
Accuracy	+/- 0.5%
Sensor type	316 SS silicon piezoresistive
Range	0,2 to 250 Bar
Electrical connection	Cable or M12 connector
Process connection	G1/4" / 1/4"-18 NPT / 1/8"-27 NPT / M14*1.5 / M12*1.5 / 1/4"-19 PT / 7/16"-20 UNF (female)
Body material	304 SS
Work temperature	-10 to +80°C
Over pressure	3 x F.S.
Class protection	IP 65

## Technical Specifications

### SP21

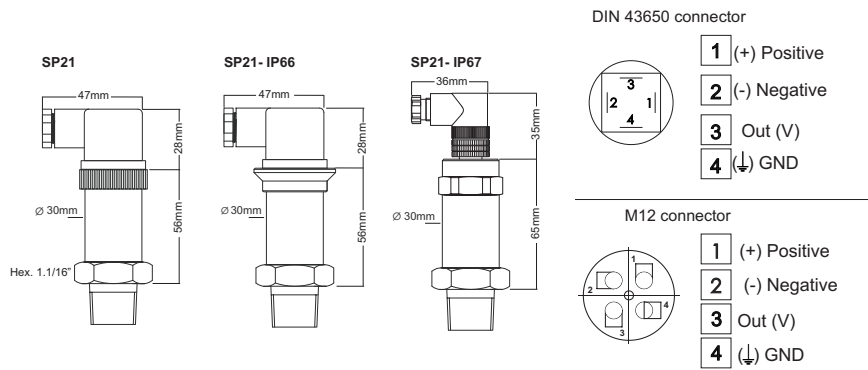

Application	Pressure and Level measurement for liquids and gas
Power supply	12...30Vdc
Consumption	22mA max.
Output	4...20mA (2 wires) 0,5...4,5/ 1...5V/ 0...5V (3 wires) upon request
Protection	Reverse polarity
Accuracy	+/- 0.25%
Sensor type	316 SS silicon piezoresistive
Range	0.1 to 1000 Bar
Electrical connection	DIN43650 or M12 connector
Process connection	BSP ou NPT - flange or sanitary
Body material	304 SS
Work temperature	-10° to + 80°C
Over pressure	3 x F.S.
Class protection	IP 65 / IP66 / IP67

## Technical Specifications

### SP98 / SP96

DIN 43650 connector

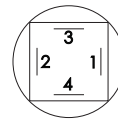
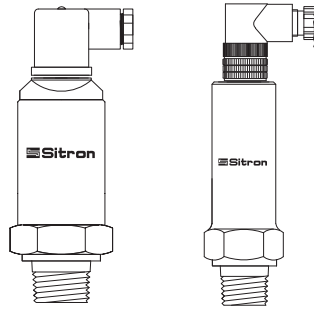

- 1** (+) Positive
- 2** (-) Negative
- 3** Out (V)
- 4** (⊥) GND

M12 connector

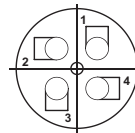

- 1** (+) Positive
- 2** (-) Negative
- 3** Out (V)
- 4** (⊥) GND

Application	Pressure and Level measurement for liquids and gas
Power supply	12...30Vdc
Consumption	22mA max.
Output	4...20mA (2 wires) or 1...5 (optional)
Accuracy	+/- 0.5%
Sensor type	SP-98 Ceramic capacitive SP-96 316 SS silicon piezoresistive.
Range	SP-98 (-1 to 40 Bar) SP-96 (-1 to 200 Bar)
Electrical connection	DIN43650 or M12 connector
Process connection	BSP or NPT, flange or sanitary
Body material	316 SS
Work temperature	-10 to +80°C
Over pressure	3 x F.S.
Class protection	IP 65

## Technical Specifications

### SP81



M12 connector

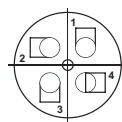

- 1 (+) Positive
- 2 (-) Negative
- 3
- 4 (⏚) GND

Application	Pressure and Level measurement for liquids and gas
Power supply	12...30Vdc
Consumption	22mA max.
Output	4...20mA (2 wires )
Protection	Reverse polarity / Electromagnetic Interference
Accuracy	+/- 0.25%
Sensor Type	Piezoresistive ceramic
Range	0...600 Bar
Electrical connection	M12 connector
Process connection	BSP, NPT, flange or sanitary
Body material	316 SS
Work temperature	-10° to + 80°C
Over pressure	3 x F.S.
Class protection	IP 67

## Trouble Shooting

<u>Fail</u>	<u>Cause</u>	<u>Solution</u>
Lack of Linearity	Deformed membrane	Call for service
	Incorrect power supply	Check the power supply
	Temperature outside the operating range	Process temperature must be within stated range
Output Signal Oscilating	Turbulence in the process	Check the installation, may need to install a stilling well
Output Signal Fixed	Deformed membrane	Call for service
	Problem with the electronics	
	Infiltration	
No Output Signal	Confirm that the unit was installed in accordance with the recommendations	

## Ordering Information

MODELS	
SP96	
SP96FA	
SP98	
SP98FA	DIMENSION
SP21	1 1/4"
SP81	2 3/8"
SP68	3 1/2"
SP30	4 3/4"
SP10	5 1"
	6 1 1/2"
	7 2"
	9 3"
PROCESS CONNECTION	
B	BSP
E	FLANGE ANSI 150# 316 SS
F	FLANGE ANSI 150# PVC
K	FLANGE ANSI 150# 316 SS
N	NPT
R	SMS Female
S	SMS Macho
T	TRI-CLAMP
Y	DIN - Female 316 SS
HOUSING	
SC	None
N1	Small Nylon
ELECTRICAL CONNECTION	
1	1/2" BSP
2	PC 1/2" BSP
7	PC 1/2" NPT
D	DIN Connector 43650
L	Cable length (especific)
Y	M16 metal w/ 2m Cable
M	M12 Connector
RANGE	
R	Especify
SENSOR TYPE	
0	None
A	316 SS Silicon (Absolute)
B	316 SS (Olive oil)
C	Ceramic
CP	PVC Body Ceramic sensor
D	316 SS Differential silicon
G	316 SS Gauge silicon
H	316 SS Gauge Olive oil
X	Others
OPTION	
F	Flush mounted membrane
P	PVC body and connection
PE	Polypropylene Body and connection
ACCESSORIES	
0	None
I	Digital indicator
X	Cable
COMMUNICATION	
HT	Hart Talker - USB / Hart Interface



## Terms & Conditions

### Sitron's TERMS & CONDITIONS

**Design:** Sitron reserves the right to make any alterations or changes necessary to improve the Products, correct defects or to make the Products safer, without prior notice or consent by Buyer.

**Pricing:** All stipulated amounts shall be in US dollars and all prices quoted are valid for thirty (30) days from date of offer, unless otherwise stated.

**Safety and Instructions:** The Buyer ensures that it and all its representatives and agents will observe all safety and technical instructions in Sitron's operating manuals, catalogs or other directions or instructions (either written or verbal).

**Delivery and Freight:** All goods are sold FOB point of shipment, Brasil. Transportation to the destination is the Buyer's responsibility and Buyer alone shall bear the cost of freight, optional or other shipping requirements, and or insurance. Sitron shall not be liable for loss or damage to the Products after said Products are delivered to or received by the shipper/carrier, and all risk of damage or loss shall immediately pass to Buyer. Receiving, unloading and storing of Products will be the responsibility of the Buyer. Buyer also accepts that courier may choose to return Products to Sitron if any local taxes or duties are not paid by Buyer at point of delivery. Buyer must make any and all claims for corrections or deductions within ten days of the delivery of the Products.

**Shipment Delays:** Sitron has no control over the length of time shipments may be held at customs, etc. For this reason, Sitron commits only to a "shipment date", not a "delivery date". Buyer shall not hold Sitron liable for claims resulting from delay in shipment except in cases where these terms are accepted in writing by Sitron. Acceptance of delivery of Products by Buyer shall constitute a waiver of all claims for delay.

**Partial Deliveries:** While Sitron strives to deliver all orders on time and complete, Sitron reserves the right to make partial deliveries when necessary.

**Changes:** Any changes initiated by the Buyer which affects the products specifications; quantities ordered; delivery schedule; method of shipment or packing; or delivery location, must be made in writing and signed by both parties.

In this case, Sitron reserves the right to adjust the pricing and or delivery of the order, which will be agreed to by both parties before further work is performed on the order. Any such requests will be priced according to the scope of changes and the status of the current order. Customer must sign and return or acknowledge approval of drawings along with any Purchase Order. If approval drawings are not returned with order, the delivery date may be held or pushed back until Customer has acknowledged approval.

**Cancellation:** Any cancellation of the Contract by the Buyer shall be effective only if made in writing and accepted, in writing by the Sitron. In such a case, Sitron is entitled to reasonable cancellation charges including but not limited to labor, material and other related expenses.

**Termination Fee Schedule:**

Order entered but not released for manufacturing	10%
Order in any stage of production	75%
Order complete and ready for shipment	100%

**Warranty:** Sitron warrants its product against manufacturing defects in material and workmanship, when installed in applications approved by Sitron, for a period of one year from the date of original shipment, unless otherwise stated in writing by Sitron.

Sitron is not responsible for damage to Sitron's Products or other equipment or products because of improper installation or misapplication of the Products by Buyer. Installation or startup of Sitron's equipment must be performed under the guidelines set forth in Sitron's instruction manuals, wiring diagrams, etc., or performed under the direct supervision of Sitron's field technicians or Sitron's authorized Sales Representatives, in order to be covered by Sitron's warranty.

Sitron shall be under no liability in respect to any defect from fair wear and tear, willful damage, negligence, abnormal working conditions, failure to follow Sitron's instructions (whether written or verbal), misuse, modification or alteration or attempted repair of the Goods without Sitron's approval.

Sitron shall not be liable under the above warranty (or any other warranty, condition or guarantee) if the total price for the Products or the payment of Services rendered has not been paid by the due date for payment.

The Buyer must make all tools, resources or personnel available to help Sitron to diagnose the defect without any back charge. In absence of Buyer's cooperation in this regard, there shall be no liability under the above Warranty.

Sitron's liability under this warranty shall be limited to repair or replacement at Sitron's option of such defective Products, FOB factory, upon proof of defect satisfactory to Sitron. Warranty does not include transport.

**Return Goods:** No goods may be returned without Sitron's permission and an RMA number. Sitron assumes no responsibility for return shipments made without permission. In issuing credit for such shipments, Sitron reserves the right to charge a restocking fee dependent on Sitron's ability to recondition and resell the returned equipment.

**Insurance:** The responsibility for insuring the Goods after the risk in them has passed to the Buyer shall be that of the Buyer.

**Confidential Information:** All drawings, specifications, and technical information provided by either Buyer or Sitron shall be treated as confidential and shall not be disclosed to anyone other than those who require it as part of the fulfillment of the order. Buyer agrees that the designs and/or any other related material provided are and remain Sitron's exclusive property and that the Buyer acquires no right, title or interest to this intellectual property, whether in whole or in part.

**Errors:** Sitron reserves the right to correct all typographical or clerical errors or omissions, in its prices or specifications.



SP\_01\_2016

Sitron - Brasil  
R. Baronesa de Itu, 83  
São Paulo - SP - 01231-001  
T: (5511) 3825-2111  
F: (5511) 3825-2171

Sitron - USA  
1800 Prime Place  
Hauppauge, NY 11788  
PH: 516-935-8001  
FX: 800-516-1656

[www.sitron.com](http://www.sitron.com)  
BRASIL: [vendas@sitron.com](mailto:vendas@sitron.com)  
USA / Other Countries: [info@sitron.com](mailto:info@sitron.com)