



User's Guide

Installation, Operation and Maintenance



CN1 & CN2

Conductive Level Switch

Contents

- Introduction 3
- Models & Dimensions 4
- Electrical Connection 6
- Mounting Notes 8
- Installation 9
- Handling 12
- Technical Specification 13
- Trouble Shooting 16
- Ordering Information 17
- Terms & Conditions 18

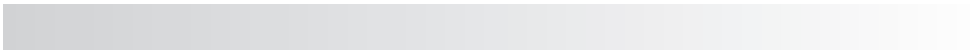

CN1 & CN2 Conductive Level Switch



Sitron's CN Series of Conductive Level Switches are designed to control the level of all conductive medium for up to two different points of level control with sensitivity control and time delay adjustment.

All CN Series units (both in AC and DC voltage supplies) come with integrated internal electronic relays within the housing. This eliminates the need for a separate remote controller. In addition, these units can be ordered with a built-in reference rod for applications in non-metallic vessel.

Models are available with rigid rods, removable rods and pendular electrodes made from 316SS. For applications with aggressive or sticky media or higher temperatures, the rods may be coated with Epoxy or Halar. The CN Series Level Switches are designed to work at temperatures of - 10° to 80° C and maximum pressures of up to 20 bar.

Technology:

The probes work by the change in electrical resistance between the electrode and reference electrode or metal wall of the vessel. When the electrode comes into contact with the conductive medium the electronics detects the change in resistance level actuating a relay output.

The electrodes are powered up with alternating current. The use of alternating current avoids the corrosive result of electrolysis on the rods.

Features

- Can operate in all conductive medias.
- Easy to install and Set up.
- Optional Epoxy or Halar coatings for aggressive medium.
- Available with 316SS, Sanitary, Flange or Threaded connections.

Models

CN1 & CN2
Fixed Rod
N1 Housing

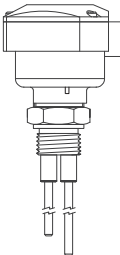

CN1 & CN2
Pendular Electrode
N1 Housing

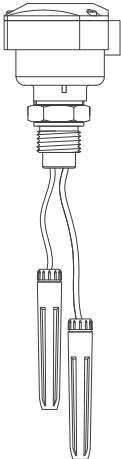

CN1 & CN2
Removable Rod
N1 Housing

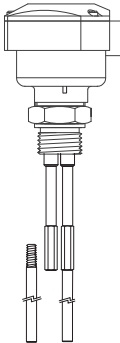

CN1 & CN2
Rigid Rod
G1 Housing

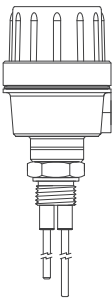

CN1 & CN2
Pendular Electrode
G1 Housing

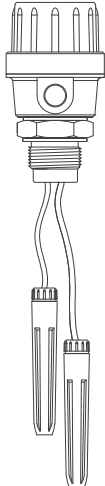

CN1 & CN2
Removable Rod
G1 Housing

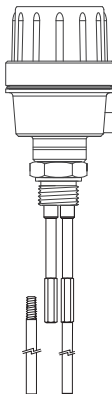

Dimensions

Mounting Options

N1 - Nylon

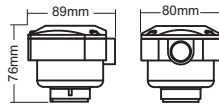

Aluminum - G1

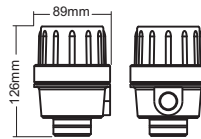

Insertion Length

CN1- Standard Fixed Rod

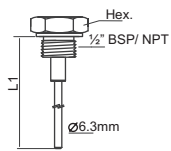

CN2- Standard Fixed Rod

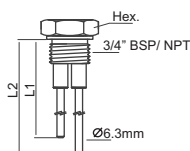

CN1- 1 1/2" Sanitary

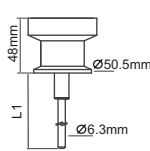

CN2- 2" Sanitary

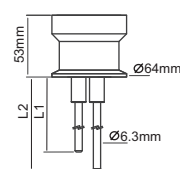

CN1- PVC cable Pendular Electrode

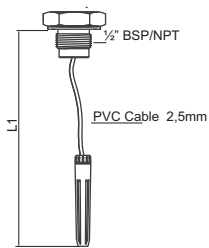

CN2- PVC cable Pendular Electrode

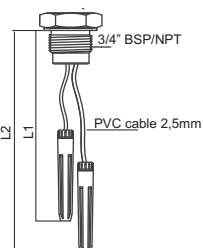

CN1 Removable Rod

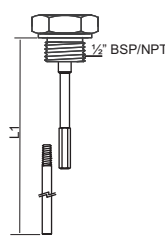

CN2 Removable Rod

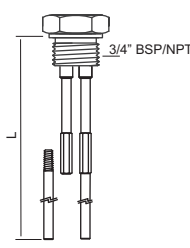

L1 to L3- Insertion Length

Process Connections

Threaded Connections

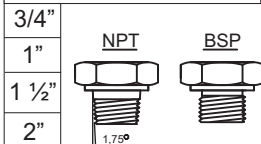

Tri-Clamp Connection

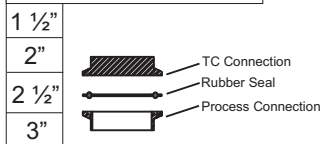

Flange Connections ANSI 150# ANSI 300#

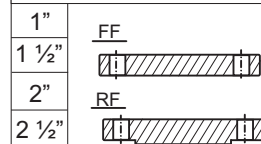

Electrical Connections

Before Powering the unit up, make sure that the Power Supply is compatible with the voltage indicated on the identification tag of the equipment

CN1 & CN2 - N1 Housing

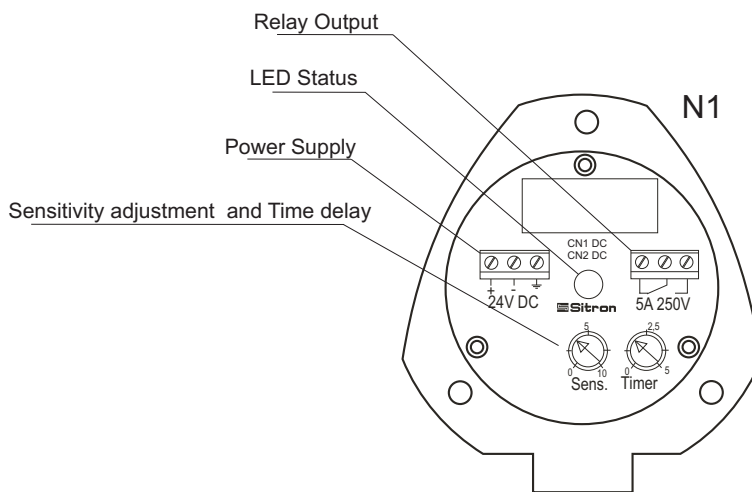

CN1 & CN2 - G1 Housing

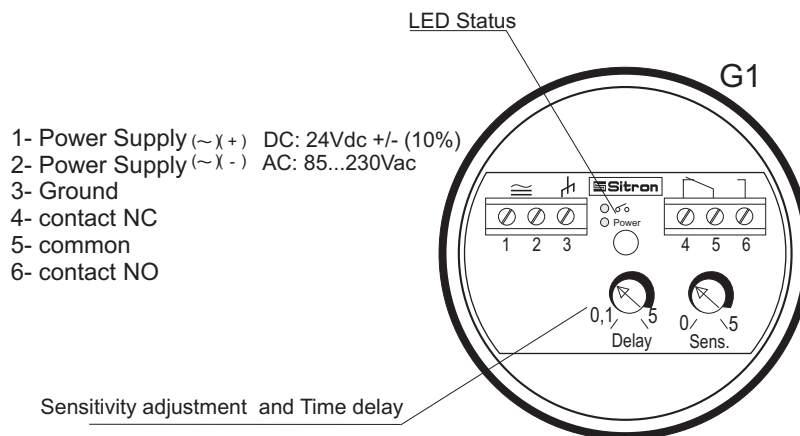

Electrical Connections

Application

CN1- When the probe is connected, the LED lights Green. When the conductive medium reaches the electrode, the relay operates and the LED lights Red.

CN2- Control min. and max. level
 When the conductive medium reaches the maximum level, the LED lights Red, turning lights Green after the conductive medium detects the rod or electrode.

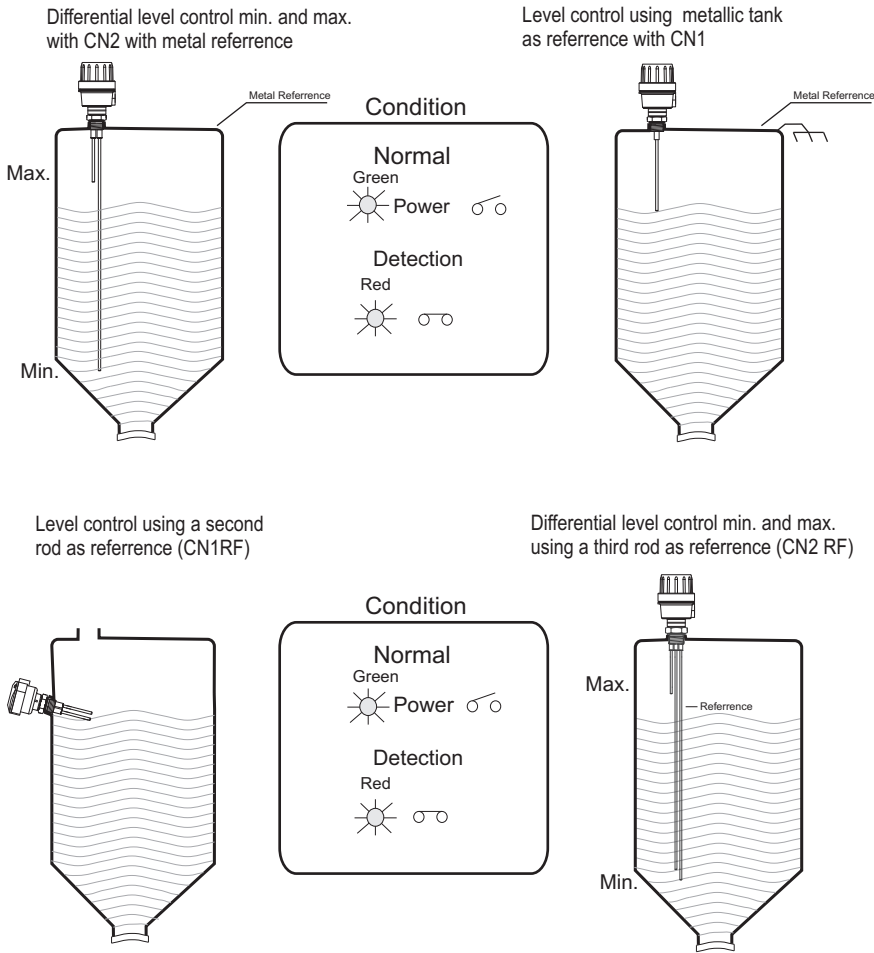

Mounting Notes

When making connections between the CN, use reliability cables and make sure they are grounded. Shielded cables prevent interference and changes in electronic improving and protecting against false detections.

Avoid radio frequency interference and possible malfunction. When possible, keep hand held communication equipment away from the CN level switch.

Do not use in harsh or humid environments. Respect class protection, working temperature and protect the same from rain and excessive heat.

A stable Power Supply prevents equipment malfunction.

Identifying rods.

In cases where the rod reference has the same length as a rod detection, an ID tag is fixed on the rods with the following code:

- (L1) for max. level
- (L2) for min. level
- (L3 + REF) Reference

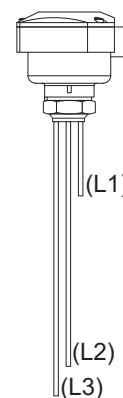
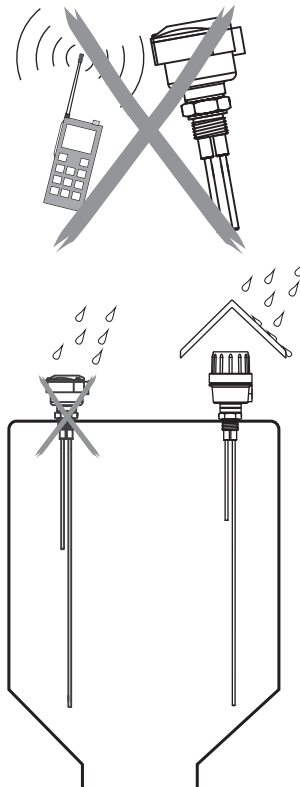

The probes may be installed in tanks or containers made of various materials such as metal, plastic, concrete etc.. For non-metallic tanks make sure that the probe has a reference rod. (Fig. 1)

The metallic tank can be used as a reference. (Fig. 2)

Evaluate the type of product to be detected in the process. The probes may require coating to protect the rod against corrosive or aggressive products or from false triggering of the relay due to moisture build-up along the length of the rod from steam. (Fig.2)

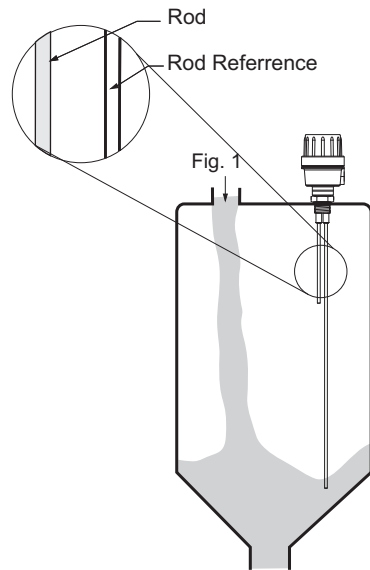

The threaded connection should be in contact with the metallic tank

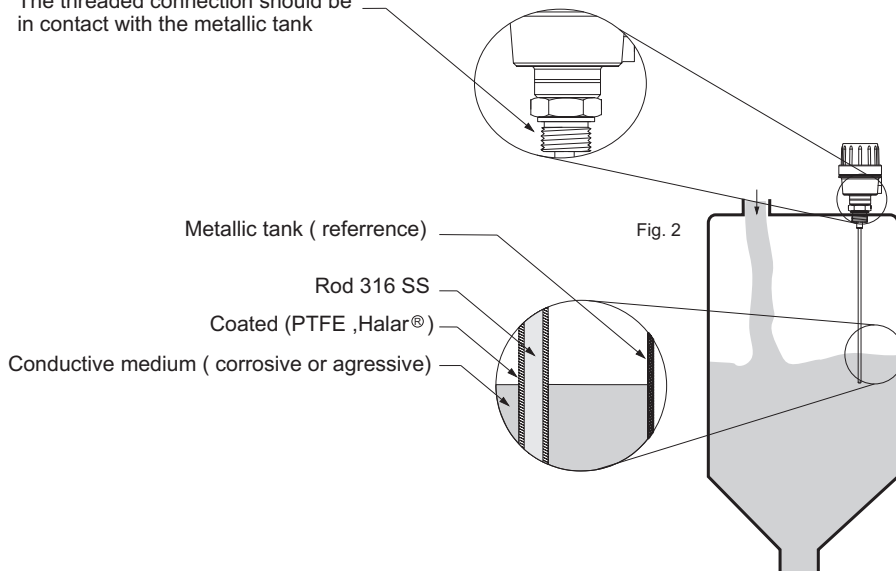

Installation

Verify that the location the probe is to be mounted is clear from the stream of product. (Fig. 1)

Material falling onto the probe can cause damage or switching errors. If this is unavoidable, it is recommended that a protective shield be installed above the probe to protect it. The shield is also recommended when the probe is used for a low level switch or in the outflow of the product. (Fig. 2)

The tip of the probe should slightly point downward (when possible) so that if there is any excess of product it will easily slide off the probe. (Fig. 2)

When installing from the top of the tank confirm that the tip of the probe has cleared the side of the vessel by at least 500mm. (Fig. 3)

When installing the sensor directly to the tank make sure that the rod extends beyond the inner wall of the tank by as much as possible, so that internal build up or other debris does not interfere with the sensor's performance. (Fig. 2 correct Fig. 4 incorrect)

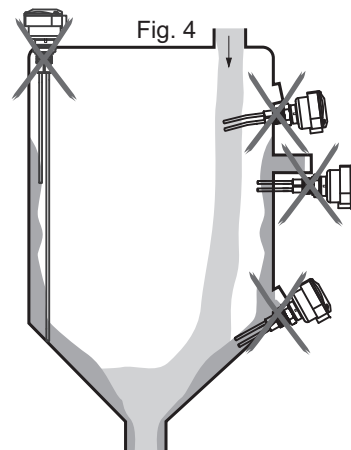
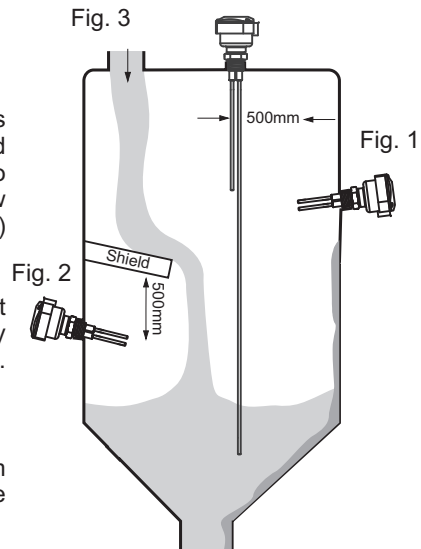

Installation

For probes with cable extensions, installation should be from the top of the tank. It is also recommended that for these probes the process shouldn't have any agitation as this can cause fluctuating readings or damage to the probe. (Fig. 5)

The CN with fixed rod is recommended for applications that have turbulence or vortices throughout use. (Fig.6)

Ensure that the conduit is facing downward to avoid water from entering the housing. (Fig. 7)

Verify that the operating pressure and temperature of the process corresponds to the operating parameters of the probe.

The probe must be installed utilizing the type of connection provided, unless an approved adaptor is provided

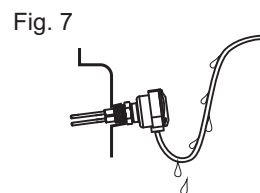
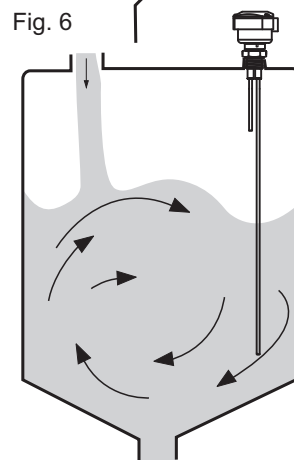
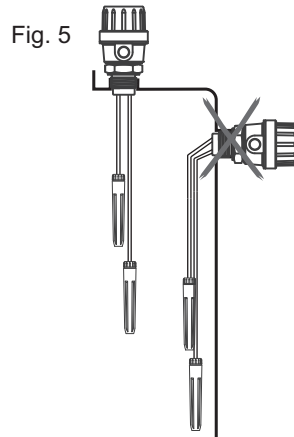

Handling

Seal the thread with Teflon tape before installation. (Fig. 1)

Fig. 1

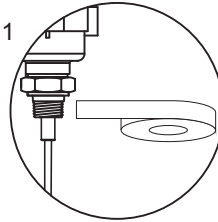

Do not turn or handle by the housing. (Fig. 2)

Fig. 2

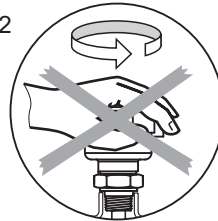

When tightening the sensor, use only use the 316S.S. hexagon fitting to achieve a seal, do not twist with the body of the sensor. (Fig. 3)

Fig. 3

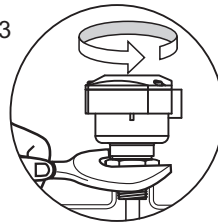

The probe should not be dropped or suffer any impact or fall that could damage the electronics or the coating of the probe. (Fig. 4 and 5)

Periodic visual inspection of the probe is required to check for corrosion or deposit build-up. If deposits are found, clean the sensor to ensure optimum performance.

Fig. 4

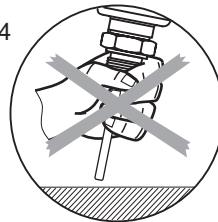

Care should be taken when handling and installing probes with coated rods to avoid scratching them. Scratching the coating could interfere with the probe performance.

Fig. 5

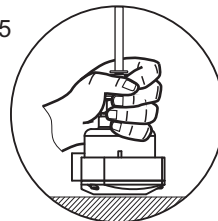

When cleaning the rod use a soft brush or any other similar object.

Technical Specification

Conductive Level Switch

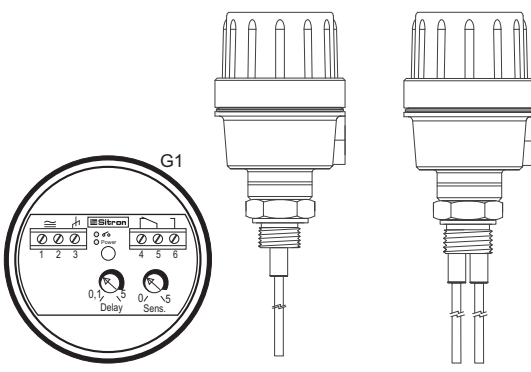
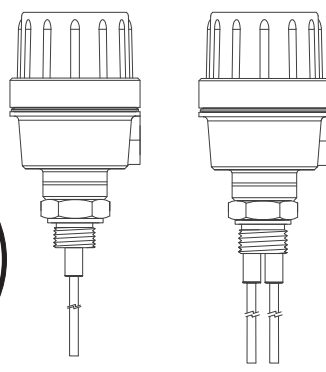
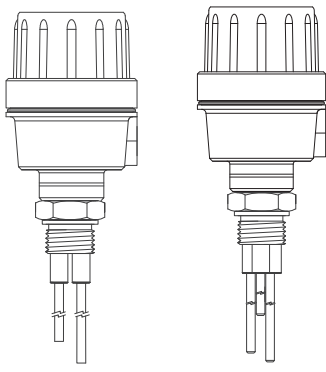
MODELS	CN1 & CN1RF AC	CN2 & CN2RF AC
		
Application	Level Detection for Conductive Medium	Level Detection for Conductive Medium
Power Supply	85...230Vac / 125Vcc	85...230Vac / 125Vcc
Consumption	2VA	2VA
Output	Relay (SPDT) 5A-250Vac	Relay (SPDT) 5A-250Vac
Ajustment	Sensibility: max 50K Ω	Sensibility: max 50K Ω
Time Delay	0.1 to 5 sec.	0.1 to 5 sec.
Housing	Aluminum	Aluminum
Electrical Connection	Cable Gland 1/2" BSP, NPT or M12 connector	Cable Gland 1/2" BSP, NPT or M12 connector
Process Connection	1/2" to 1 1/2" BSP or NPT, Flange and Sanitary	3/4" to 1 1/2" BSP or NPT, Flange and Sanitary
Wetted Parts	316 SS	316 SS
Work Temperature	-10 to +80°C	-10 to +80°C
Max. Pressure	20 bar	20 bar
Class Protection	IP 65	IP 65

Technical Specification

Conductive Level Switch

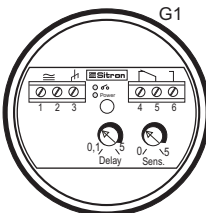
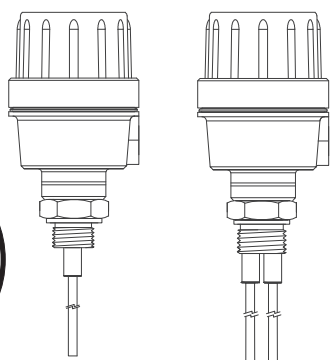
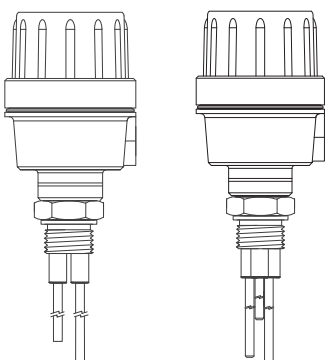
MODELS	CN1 & CN1RF DC	CN2 & CN2RF DC
		
Application	Level Detection for Conductive Medium	Level Detection for Conductive Medium
Power Supply	24Vdc (+/- 10%)	24Vdc (+/- 10%)
Consumption	2VA	2VA
Output	Relay (SPDT) 5A-250Vac	Relay (SPDT) 5A-250Vac
Ajustment	Sensibility: max 50K Ω	Sensibility: max 50K Ω
Time Delay	0.1 to 5 sec.	0.1 to 5 sec.
Housing	Aluminum	Aluminum
Electrical Connection	Cable Gland 1/2" BSP, NPT or M12 connector	Cable Gland 1/2" BSP, NPT or M12 connector
Process Connection	1/2" to 1 1/2" BSP or NPT, Flange and Sanitary	3/4" to 1 1/2" BSP or NPT, Flange and Sanitary
Wetted Parts	316 SS	316 SS
Work Temperature	-10 to +80°C	-10 to +80°C
Max. Pressure	20 bar	20 bar
Class Protection	IP 65	IP 65

Technical Specification

Conductive Level Switch

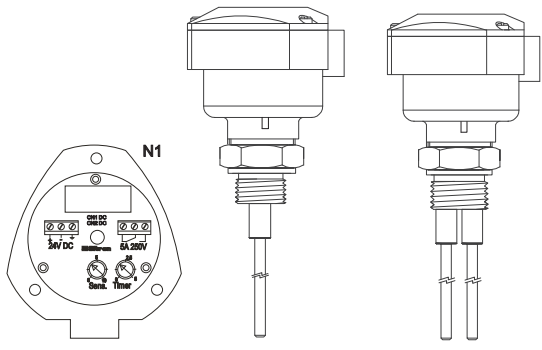
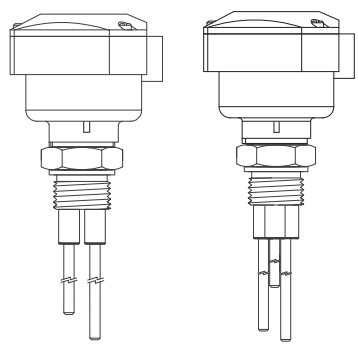
MODELS	CN1 & CN1RF DC	CN2 & CN2RF DC
		
Application	Level Detection for Conductive Medium	Level Detection for Conductive Medium
Power Supply	24Vdc (+/- 10%)	24Vdc (+/- 10%)
Consumption	2VA	2VA
Output	Relay (SPDT) 5A-250Vac	Relay (SPDT) 5A-250Vac
Ajustment	Sensibility: max 50K Ω	Sensibility: max 50K Ω
Time Delay	0.1 to 5 sec.	0.1 to 5 sec.
Housing	Nylon Fiberglass	Nylon Fiberglass
Electrical Connection	Cable Gland 1/2" BSP, NPT or M12 connector	Cable Gland 1/2" BSP, NPT or M12 connector
Process Connection	1/2" to 1 1/2" BSP or NPT, Flange and Sanitary	3/4" to 1 1/2" BSP or NPT, Flange and Sanitary
Wetted Parts	316 SS	316 SS
Work Temperature	-10 to +80°C	-10 to +80°C
Max. Pressure	20 bar	20 bar
Class Protection	IP 65	IP 65

Trouble Shooting

Fail	Cause	Solution
Probe does not work	LED of Power supply indication does not turn on	Check the Power supply
	LED of level indication does not ON	Check cable resistance (max. must be 50kΩ)
		Check the sensibility
Probe continuously ON	LED of level indication always ON	Check the adjustment of sensibility
		Check the temperature of liquid medium. If there is presence of steam it is necessary coat the rods
		Check if there is build up on the rod

Ordering Information

MODEL	
CN1DC	
CN1DCRF	
CN2DC	
CN2DCRF	
CN1AC	
CN1ACRF	
CN2AC	
CN2ACRF	
SIZE	
0	NONE
3	1/2"
4	3/4"
5	1"
6	1 1/2"
7	2"
8	2 1/2"
9	3"
A	1 1/4"
B	M30(E)
Q	4"
X	OTHER
PROCESS CONNECTION TYPE	
B	BSP
D	FLANGE ANSI 150# CARBON STEEL PAINTED
E	FLANGE ANSI 150# 316 SS
F	FLANGE ANSI 150# - PVC
M	METRIC THREAD
K	FLANGE ANSI 150# - 304 SS
N	NPT
R	SMS FEMALE
S	SMS MALE
T	TRI CLAMP
U	NK25
Y	FEMALE DIN 316SS
X	OTHER SPECIFY
TYPE OF ROD OR CABLE	
O	NONE
A	FIXED ROD 1/4" - 316 SS
L	REMOVABLE ROD 1/4" - 316 SS
N	PVC CABLE
S	SILICON CABLE 2.5mm
U	REFERENCE CABLE 5/32" - 316 SS
X	OTHER
COATING/ TUBING	
S	NONE
E	EPOXY (up to 120°C)
H	COATED HALLAR (up to 150°C)
N	NYLON
P	PEEK (up to 260° C)
X	OTHER SPECIFY
INSERTION LENGTH	
L	SPECIFY
HOUSING	
N1	SMALL NYLON
G1	SMALL ALUMINUM
ELECTRICAL CONNECTION	
1	1/2" BSP (N1 OR G1)
2	CABLE GLAND W/ 1/2" BSP
3	3/4" BSP (G1)
5	CABLE GLAND W/ 3/4" BSP (G1)
6	1/2" NPT (N1 OR G1)
7	CABLE GLAND W/ 1/2" NPT
8	1/2" NPT CABLE GLAND & 2m CABLE
9	3/4" NPT (G1)
C	CLIMPED W/ 2m OF CABLE (EL - SC)
Y	CABLE GLAND W/ M16 METAL (A1)
OPTIONS	
O	NONE
A	CLAMP
E	SINGLE ELECTRODE IN A POLIPROPELENE ENCLOSURE
F	O'RING VITON OR TEFLON
L	ADAPTOR
MT	MEDIUM TEMPERATURE - 50mm 316 SS NECK (80-120°C)
AT	HIGHT TEMPERATURE - 100mm 316 SS NECK (80-150°C)
N	NIPPLE FOR NK25 (1/2"BSP)
S	SANITARY NIPPLE

Terms & Conditions

Sitron's TERMS & CONDITIONS

Design: Sitron reserves the right to make any alterations or changes necessary to improve the Products, correct defects or to make the Products safer, without prior notice or consent by Buyer.

Pricing: All stipulated amounts shall be in US dollars and all prices quoted are valid for thirty (30) days from date of offer, unless otherwise stated.

Safety and Instructions: The Buyer ensures that it and all its representatives and agents will observe all safety and technical instructions in Sitron's operating manuals, catalogs or other directions or instructions (either written or verbal).

Delivery and Freight: All goods are sold FOB point of shipment, Brasil. Transportation to the destination is the Buyer's responsibility and Buyer alone shall bear the cost of freight, optional or other shipping requirements, and or insurance. Sitron shall not be liable for loss or damage to the Products after said Products are delivered to or received by the shipper/carrier, and all risk of damage or loss shall immediately pass to Buyer.

Receiving, unloading and storing of Products will be the responsibility of the Buyer.

Buyer also accepts that courier may choose to return Products to Sitron if any local taxes or duties are not paid by Buyer at point of delivery. Buyer must make any and all claims for corrections or deductions within ten days of the delivery of the Products.

Shipment Delays: Sitron has no control over the length of time shipments may be held at customs, etc. For this reason, Sitron commits only to a "shipment date", not a "delivery date". Buyer shall not hold Sitron liable for claims resulting from delay in shipment except in cases where these terms are accepted in writing by Sitron. Acceptance of delivery of Products by Buyer shall constitute a waiver of all claims for delay.

Partial Deliveries: While Sitron strives to deliver all orders on time and complete, Sitron reserves the right to make partial deliveries when necessary.

Changes: Any changes initiated by the Buyer which affects the products specifications; quantities ordered; delivery schedule; method of shipment or packing; or delivery location, must be made in writing and signed by both parties.

In this case, Sitron reserves the right to adjust the pricing and or delivery of the order, which will be agreed to by both parties before further work is performed on the order. Any such requests will be priced according to the scope of changes and the status of the current order. Customer must sign and return or acknowledge approval of drawings along with any Purchase Order. If approval drawings are not returned with order, the delivery date may be held or pushed back until Customer has acknowledged approval.

Cancellation: Any cancellation of the Contract by the Buyer shall be effective only if made in writing and accepted, in writing by the Sitron. In such a case, Sitron is entitled to reasonable cancellation charges including but not limited to labor, material and other related expenses.

Terms & Conditions

Termination Fee Schedule:

Order entered but not released for manufacturing	10%
Order in any stage of production	75%
Order complete and ready for shipment	100%

Warranty: Sitron warrants its product against manufacturing defects in material and workmanship, when installed in applications approved by Sitron, for a period of one year from the date of original shipment, unless otherwise stated in writing by Sitron.

Sitron is not responsible for damage to Sitron's Products or other equipment or products because of improper installation or misapplication of the Products by Buyer. Installation or startup of Sitron's equipment must be performed under the guidelines set forth in Sitron's instruction manuals, wiring diagrams, etc., or performed under the direct supervision of Sitron's field technicians or Sitron's authorized Sales Representatives, in order to be covered by Sitron's warranty.

Sitron shall be under no liability in respect to any defect from fair wear and tear, willful damage, negligence, abnormal working conditions, failure to follow Sitron's instructions (whether written or verbal), misuse, modification or alteration or attempted repair of the Goods without Sitron's approval.

Sitron shall not be liable under the above warranty (or any other warranty, condition or guarantee) if the total price for the Products or the payment of Services rendered has not been paid by the due date for payment.

The Buyer must make all tools, resources or personnel available to help Sitron to diagnose the defect without any back charge. In absence of Buyer's cooperation in this regard, there shall be no liability under the above Warranty.

Sitron's liability under this warranty shall be limited to repair or replacement at Sitron's option of such defective Products, FOB factory, upon proof of defect satisfactory to Sitron. Warranty does not include transport.

Return Goods: No goods may be returned without Sitron's permission and an RMA number. Sitron assumes no responsibility for return shipments made without permission. In issuing credit for such shipments, Sitron reserves the right to charge a restocking fee dependent on Sitron's ability to recondition and resell the returned equipment.

Insurance: The responsibility for insuring the Goods after the risk in them has passed to the Buyer shall be that of the Buyer.

Confidential Information: All drawings, specifications, and technical information provided by either Buyer or Sitron shall be treated as confidential and shall not be disclosed to anyone other than those who require it as part of the fulfillment of the order. Buyer agrees that the designs and/or any other related material provided are and remain Sitron's exclusive property and that the Buyer acquires no right, title or interest to this intellectual property, whether in whole or in part.

Errors: Sitron reserves the right to correct all typographical or clerical errors or omissions, in its prices or specifications.



CN_REV1_01_2014

Sitron - Brasil
R. Baronesa de Itu, 83
São Paulo - SP - 01231-001
T: (5511) 3825-2111
F: (5511) 3825-2171

Sitron - USA
1800 Prime Place
Hauppauge, NY 11788
PH: 516-935-8001
FX: 800-516-1656

www.sitron.com
BRASIL: vendas@sitron.com
USA / Other Countries: info@sitron.com