

VTK Tuning Fork Point Level Detection

Characteristics

- Explosion-proof housing (EX d)
- Robust with no moving parts
- Corrosion Resistant 316 SS Body
- Forks can be Halar coated for corrosive media
- Un-affected by either the dielectric or the conductivity of the medium.
- Protection Class IP66 (IEC 60529).
- Signal Output.
 - Relay NO + NC
- Protection:
 - Reverse Polarity
 - Voltage Surge
 - Electromagnetic Interference
- Various types of process connections:
Thread, Flange and Sanitary
- Viewing window for visual indication of LED status



Description

Sitron VTK series of vibrating tuning forks are an ideal solution for many point level detection applications because they are un-affected by either the dielectric or the conductivity of the medium. When the tuning fork is submerged in the medium the frequency at which it vibrates changes. This change is detected by the unit's electronics and is converted into a switch output, relay. Users around the world have come to depend on this technology as one that is easy to apply and very reliable.

All models are made in 316 Stainless Steel, can be ordered with a great variety of threaded, flange, or hygienic fittings, are available with Halar or epoxy coatings and can operate at temperatures up to 120°C (248°F). All models (except the mini-versions) have a time delay adjustment of 1, 5, 10 or 20 seconds as well as a Wet/Dry selection for both High and Low level application requirements.

The GX comes standard with a glass window which enables visualization of LED switch status. The GX housing comes with the following certifications: UL, CUL, IECEX and ATEX for installation in hazardous environments.

Dimensions (mm)

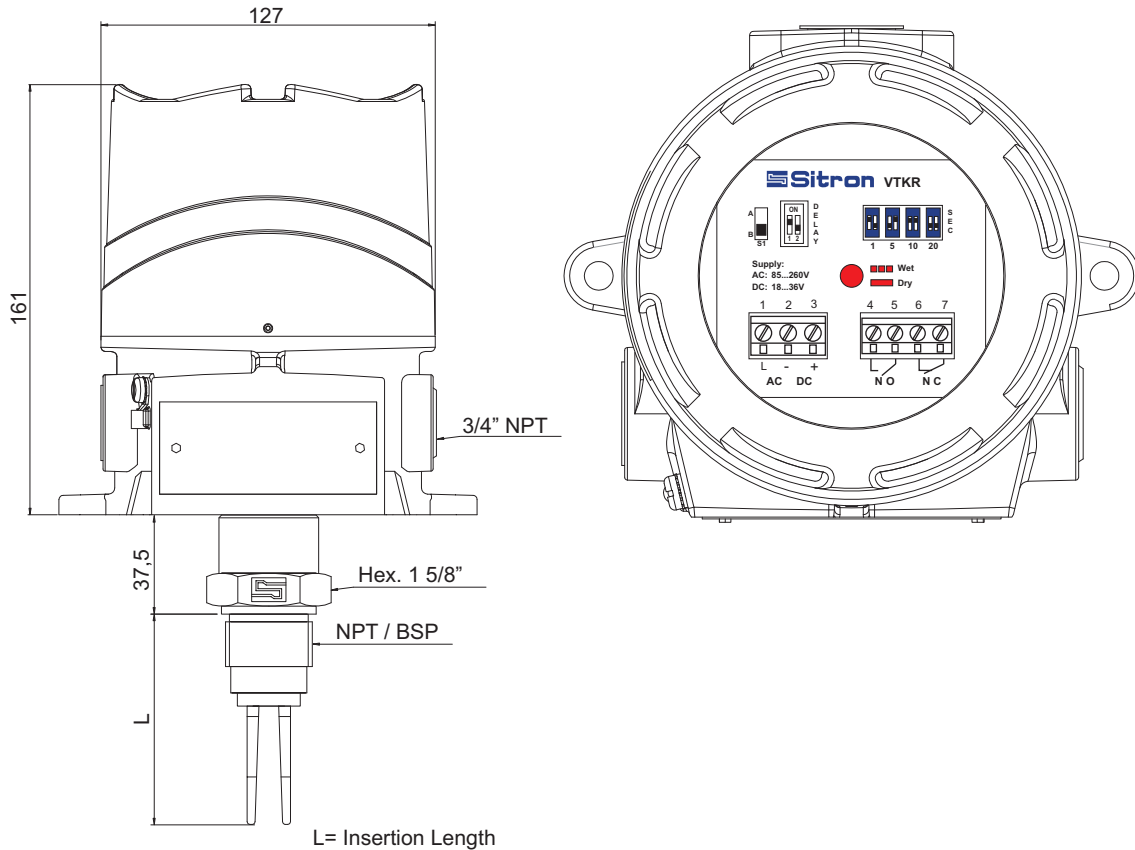

Technical Specifications

VTK-X-X-X-X-GX

Application: Level detection for Liquids

Supply: DC: 18...36Vdc ($\pm 10\%$)

AC: 85...260Vac (50/60hz)

Consumption: 10mA max.

Output: Relay NO + NC (5A - 250Vac)

Accuracy: $\pm 0.1\%$

Repeatability: < 0.5mm

Delay: 1 to 20 sec (adjustable)

Set point: 13mm from tip

Housing: Aluminum GX with glass viewing window

Electrical Connection (cable entry): 2 x 3/4" NPT

Process Connection: BSP, NPT, Flange or Sanitary

Body material: 316 SS (Hallar coating for corrosive medium upon request)

Work Temperature: -10 to + 80°C

Max Pressure: 50 Bar

Class Protection: IP66

Approvals EX proof Housing (Optional): ATEX, DEMKO 07 ATEX 0622294,

0539 II 2 G EX d IIC Gb

0539 II 2 D Ex tb IIIC Db

IECEX

IECx UL 08.0005U

Ex d IIC Gb

Ex tb IIIC Db

Classifications: Class I, Div. 1, Groups B, C, D

Class II, Div. 1, Groups E, F, G

Class III

NEMA Type 4X: Class I Zone 1 AEx d IIC

Ex d IIC (canada)

Order Code

MODEL							
VTKR							
SIZE							
4	3/4"						
5	1"						
6	1 1/2"	PROCESS CONNECTION TYPE					
7	2"	B	BSP				
9	3"	N	NPT				
Q	4"	D	FLANGE ANSI 150# - Carbon Steel Painted				
X	OTHER	E	FLANGE ANSI 150# - 316 SS				
		G	FLANGE ANSI 300# - Carbon Steel Painted				
		H	FLANGE ANSI 300# - 316 SS				
		K	FLANGE ANSI 150# - 304 SS				
		L	FLANGE ANSI 300# - 304 SS				
		T	TRI-CLAMP				
		X	OTHER - SPECIFY				
		COATING					
		S	NONE				
		H	HALAR [®] Coated				
		E	EPOXY Coated				
		P	Polished				
		X	OTHER - SPECIFY				
		INSERTION LENGTH					
		L80	L=3 1/8" (80mm) - Standard				
		L64	L=64mm - Standard (Sanitary connection)				
		L	SPECIFY				
		HOUSING					
		GX	Ex proof				
		ELECTRICAL CONNECTION					
		1	3/4" NPT				
		ACCESSORIES					
		A	Clamp				
		B	Sanitary Nipple - 1"BSP				
		F	O'ring seal for clamp				
		S	Sanitary Nipple - TC Connections				
		MT	Medium Temp - 50mm 316SS Neck (up to 100C)				
		HT	High Temp - 100mm 316SS Neck (up to 120C)				
		0	NONE				